

Introduction to Unification Theory

Solving Systems of Linear Diophantine Equations

Temur Kutsia

RISC, Johannes Kepler University of Linz, Austria
kutsia@risc.jku.at



ACU-Unification

- ▶ We saw an example how to solve ACU-unification problem.
- ▶ Reduction to systems of linear Diophantine equations (LDEs) over natural numbers.



Elementary ACU-Unification

- ▶ Elementary ACU-unification problem

$$\{f(x, f(x, y)) \stackrel{?}{\dot{=} }_{ACU} f(z, f(z, z))\}$$

reduces to homogeneous linear Diophantine equation

$$2x + y = 3z.$$

- ▶ Each equation in the unification problem gives rise to one linear Diophantine equation.
- ▶ A most general ACU-unifier is obtained by combining all the unifiers corresponding to the minimal solutions of the system of LDEs.



Elementary ACU-Unification

- ▶ $\Gamma = \{f(x, f(x, y)) \stackrel{?}{\doteq}_{ACU} f(z, f(z, z))\}$ and $S = \{2x + y = 3z\}$.
- ▶ S has three minimal solutions: $(1, 1, 1)$, $(0, 3, 1)$, $(3, 0, 2)$.
- ▶ Three unifiers of Γ :

$$\sigma_1 = \{x \mapsto v_1, y \mapsto v_1, z \mapsto v_1\}$$

$$\sigma_2 = \{x \mapsto e, y \mapsto f(v_2, f(v_2, v_2)), z \mapsto v_2\}$$

$$\sigma_3 = \{x \mapsto f(v_3, f(v_3, v_3)), y \mapsto e, z \mapsto f(v_3, v_3)\}$$

- ▶ A most general unifier of Γ :

$$\sigma = \{x \mapsto f(v_1, f(v_3, f(v_3, v_3))), y \mapsto f(v_1, f(v_2, f(v_2, v_2))), \\ z \mapsto f(v_1, f(v_2, f(v_3, v_3)))\}$$



ACU-Unification with constants

- ▶ ACU-unification problem with constants

$$\Gamma = \{f(x, f(x, y)) \stackrel{?}{\doteq}_{ACU} f(a, f(z, f(z, z)))\}$$

reduces to inhomogeneous linear Diophantine equation

$$S = \{2x + y = 3z + 1\}.$$

- ▶ The minimal nontrivial natural solutions of S are $(0, 1, 0)$ and $(2, 0, 1)$.



ACU-Unification with constants

- ▶ ACU-unification problem with constants

$$\Gamma = \{f(x, f(x, y)) \stackrel{?}{\doteq}_{ACU} f(a, f(z, f(z, z)))\}$$

reduces to inhomogeneous linear Diophantine equation

$$S = \{2x + y = 3z + 1\}.$$

- ▶ Every natural solution of S is obtained by as the sum of one of the minimal solution and a solution of the corresponding homogeneous LDE $2x + y = 3z$.
- ▶ One element of the minimal complete set of unifiers of Γ is obtained from the combination of one minimal solution of S with the set of all minimal solutions of $2x + y = 3z$.



ACU-Unification with constants

- ▶ ACU-unification problem with constants

$$\Gamma = \{f(x, f(x, y)) \stackrel{?}{\doteq}_{ACU} f(a, f(z, f(z, z)))\}$$

reduces to inhomogeneous linear Diophantine equation

$$S = \{2x + y = 3z + 1\}.$$

- ▶ The minimal complete set of unifiers of Γ is $\{\sigma_1, \sigma_2\}$, where

$$\begin{aligned}\sigma_1 &= \{x \mapsto f(v_1, f(v_3, f(v_3, v_3))), \\ &\quad y \mapsto f(a, f(v_1, f(v_2, f(v_2, v_2))), \\ &\quad z \mapsto f(v_1, f(v_2, f(v_3, v_3)))\} \\ \sigma_2 &= \{x \mapsto f(a, f(a, f(v_1, f(v_3, f(v_3, v_3))))), \\ &\quad y \mapsto f(v_1, f(v_2, f(v_2, v_2))), \\ &\quad z \mapsto f(a, f(v_1, f(v_2, f(v_3, v_3))))\}\end{aligned}$$



How to Solve Systems of LDEs over Naturals?

Contejean-Devie Algorithm:



Evelyne Contejean and Hervé Devie.

An Efficient Incremental Algorithm for Solving Systems of
Linear Diophantine Equations.

Information and Computation 113(1): 143–172 (1994).



How to Solve Systems of LDEs over Naturals?

Contejean-Devie Algorithm:



Evelyne Contejean and Hervé Devie.

An Efficient Incremental Algorithm for Solving Systems of Linear Diophantine Equations.

Information and Computation 113(1): 143–172 (1994).

Generalizes Fortenbacher's Algorithm for solving a single equation:



Michael Clausen and Albrecht Fortenbacher.

Efficient Solution of Linear Diophantine Equations.

J. Symbolic Computation 8(1,2): 201–216 (1989).



Homogeneous Case

Homogeneous linear Diophantine system with m equations and n variables:

$$\begin{cases} a_{11}x_1 + \cdots + a_{1n}x_n = 0 \\ \vdots \\ a_{m1}x_1 + \cdots + a_{mn}x_n = 0 \end{cases}$$

- ▶ a_{ij} 's are integers.
- ▶ Looking for nontrivial natural solutions.



Homogeneous Case

Example

$$\begin{cases} -x_1 + x_2 + 2x_3 - 3x_4 = 0 \\ -x_1 + 3x_2 - 2x_3 - x_4 = 0 \end{cases}$$

Nontrivial solutions:

- ▶ $s_1 = (0, 1, 1, 1)$
- ▶ $s_2 = (4, 2, 1, 0)$
- ▶ $s_3 = (0, 2, 2, 2)$
- ▶ $s_4 = (8, 4, 2, 0)$
- ▶ $s_5 = (4, 3, 2, 1)$
- ▶ $s_6 = (8, 5, 3, 1)$
- ▶ ...



Homogeneous Case

Example

$$\begin{cases} -x_1 + x_2 + 2x_3 - 3x_4 = 0 \\ -x_1 + 3x_2 - 2x_3 - x_4 = 0 \end{cases}$$

Nontrivial solutions:

- ▶ $s_1 = (0, 1, 1, 1)$
- ▶ $s_2 = (4, 2, 1, 0)$
- ▶ $s_3 = (0, 2, 2, 2) = 2s_1$
- ▶ $s_4 = (8, 4, 2, 0) = 2s_2$
- ▶ $s_5 = (4, 3, 2, 1) = s_1 + s_2$
- ▶ $s_6 = (8, 5, 3, 1) = s_1 + 2s_2$
- ▶ ...



Homogeneous Case

Homogeneous linear Diophantine system with m equations and n variables:

$$\begin{cases} a_{11}x_1 + \cdots + a_{1n}x_n = 0 \\ \vdots \\ a_{m1}x_1 + \cdots + a_{mn}x_n = 0 \end{cases}$$

- ▶ a_{ij} 's are integers.
- ▶ Looking for a **basis** in the set of nontrivial natural solutions.



Homogeneous Case

Homogeneous linear Diophantine system with m equations and n variables:

$$\begin{cases} a_{11}x_1 + \cdots + a_{1n}x_n = 0 \\ \vdots \\ a_{m1}x_1 + \cdots + a_{mn}x_n = 0 \end{cases}$$

- ▶ a_{ij} 's are integers.
- ▶ Looking for a **basis** in the set of nontrivial natural solutions.
- ▶ Does it exist?



Homogeneous Case

The basis in the set S of nontrivial natural solutions of a homogeneous LDS is the set of \gg -minimal elements S .

\gg is the ordering on tuples of natural numbers:

$$(x_1, \dots, x_n) \gg (y_1, \dots, y_n)$$

if and only if

- ▶ $x_i \geq y_i$ for all $1 \leq i \leq n$ and
- ▶ $x_i > y_i$ for some $1 \leq i \leq n$.



Matrix Form

Homogeneous linear Diophantine system with m equations and n variables:

$$Ax_{\downarrow} = 0_{\downarrow},$$

where

$$A := \begin{pmatrix} a_{11} & \cdots & a_{1n} \\ \vdots & & \vdots \\ a_{m1} & \cdots & a_{mn} \end{pmatrix} \quad x_{\downarrow} := \begin{pmatrix} x_1 \\ \vdots \\ x_n \end{pmatrix} \quad 0_{\downarrow} := \begin{pmatrix} 0 \\ \vdots \\ 0 \end{pmatrix}$$



Matrix Form

- ▶ Canonical basis in \mathbb{N}^n : $(e_{1\downarrow}, \dots, e_{n\downarrow})$.

- ▶ $e_{j\downarrow} = \begin{pmatrix} 0 \\ \vdots \\ 1 \\ \vdots \\ 0 \end{pmatrix}$, with 1 in j 's row.

- ▶ Then $Ax_{\downarrow} = x_1 A e_{1\downarrow} + \dots + x_n A e_{n\downarrow}$.



Matrix Form

- ▶ a : The linear mapping associated to A .

$$a(x_{\downarrow}) = \begin{pmatrix} a_{11}x_1 & + \cdots + & a_{1n}x_n \\ \vdots & & \vdots \\ a_{m1}x_1 & + \cdots + & a_{mn}x_n \end{pmatrix} = x_1 a(e_{1\downarrow}) + \cdots + x_n a(e_{n\downarrow}).$$



Single Equation: Idea

Case $m = 1$: Single homogeneous LDE $a_1x_1 + \cdots + a_nx_n = 0$.

Fortenbacher's idea:

- ▶ Search minimal solutions starting from the elements in the canonical basis of \mathbb{N}^n .
- ▶ Suppose the current vector v_{\downarrow} is not a solution.
- ▶ It can be nondeterministically increased, component by component, until it becomes a solution or greater than a solution.
- ▶ To decrease the search space, the following restrictions can be imposed:
 - ▶ If $a(v_{\downarrow}) > 0$, then increase by one some v_j with $a_j < 0$.
 - ▶ If $a(v_{\downarrow}) < 0$, then increase by one some v_j with $a_j > 0$.



Single Equation: Idea

Case $m = 1$: Single homogeneous LDE $a_1x_1 + \cdots + a_nx_n = 0$.

Fortenbacher's idea:

- ▶ Search minimal solutions starting from the elements in the canonical basis of \mathbb{N}^n .
- ▶ Suppose the current vector v_{\downarrow} is not a solution.
- ▶ It can be nondeterministically increased, component by component, until it becomes a solution or greater than a solution.
- ▶ To decrease the search space, the following restrictions can be imposed:
 - ▶ If $a(v_{\downarrow}) > 0$, then increase by one some v_j with $a_j < 0$.
 - ▶ If $a(v_{\downarrow}) < 0$, then increase by one some v_j with $a_j > 0$.
 - ▶ (If $a(v_{\downarrow})a(e_{j_{\downarrow}}) < 0$ for some j , increase v_j by one.)



Single Equation: Geometric Interpretation of the Idea

- ▶ Fortenbacher's condition

If $a(v_{\downarrow})a(e_{j\downarrow}) < 0$ for some j , increase v_j by one.

- ▶ Increasing v_j by one: $a(v_{\downarrow} + e_{j\downarrow}) = a(v_{\downarrow}) + a(e_{j\downarrow})$.

- ▶ Going to the “right direction”, towards the origin.

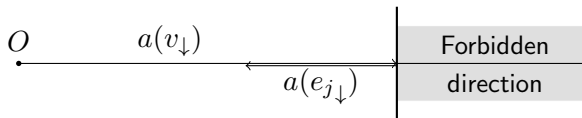

Single Equation: Algorithm

Case $m = 1$: Single homogeneous LDE $a_1x_1 + \dots + a_nx_n = 0$.

Fortenbacher's algorithm:

- ▶ Start with the pair P, M of the set of potential solutions $P = \{e_{1\downarrow}, \dots, e_{n\downarrow}\}$ and the set of minimal nontrivial solutions $M = \emptyset$.
- ▶ Apply repeatedly the rules:
 1. $\{v_\downarrow\} \cup P', M \implies P', M$,
if $v_\downarrow \gg u_\downarrow$ for some $u_\downarrow \in M$.
 2. $\{v_\downarrow\} \cup P', M \implies P', \{v_\downarrow\} \cup M$,
if $a(v_\downarrow) = 0$ and rule 1 is not applicable.
 3. $P, M \implies \{v_\downarrow + e_{j\downarrow} \mid v_\downarrow \in P, a(v_\downarrow)a(e_{j\downarrow}) < 0, j \in 1..n\}, M$,
if rules 1 and 2 are not applicable.
- ▶ If \emptyset, M is reached, return M .



System of Equations: Idea

- ▶ General case: System of homogeneous LDEs.
- ▶ $a(x_{\downarrow}) = 0_{\downarrow}$.
- ▶ Generalizing Fortenbacher's idea:
 - ▶ Search minimal solutions starting from the elements in the canonical basis of \mathbb{N}^n .
 - ▶ Suppose the current vector v_{\downarrow} is not a solution.
 - ▶ It can be nondeterministically increased, component by component, until it becomes a solution or greater than a solution.
 - ▶ To decrease the search space, increase only those components that lead to the “right direction”.



System of Equations: How to Restrict

- ▶ “Right direction”: Towards the origin.
- ▶ If $a(v_{\downarrow}) \neq 0_{\downarrow}$, then do $a(v_{\downarrow} + e_{j\downarrow}) = a(v_{\downarrow}) + a(e_{j\downarrow})$.
- ▶ $a(v_{\downarrow}) + a(e_{j\downarrow})$ should lie in the half-space containing O .
- ▶ **Contejean-Devie condition:** If $a(v_{\downarrow}) \cdot a(e_{j\downarrow}) < 0$ for some j , increase v_j by one. (\cdot is the scalar product.)

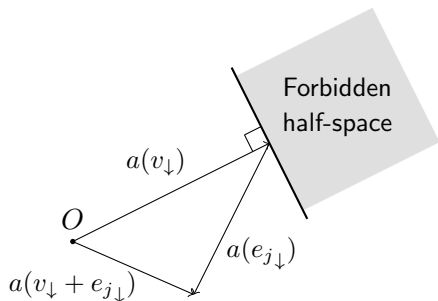

How to Restrict: Comparison

- ▶ Fortenbacher's condition

If $a(v_{\downarrow})a(e_{j\downarrow}) < 0$ for some j , increase v_j by one.

- ▶ Contejean-Devie condition

If $a(v_{\downarrow}) \cdot a(e_{j\downarrow}) < 0$ for some j , increase v_j by one.



How to Restrict: Comparison

Fortenbacher's condition

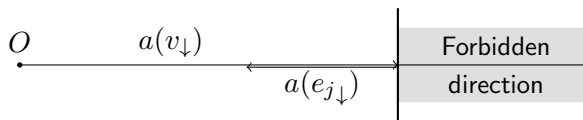

Contejean-Devie condition

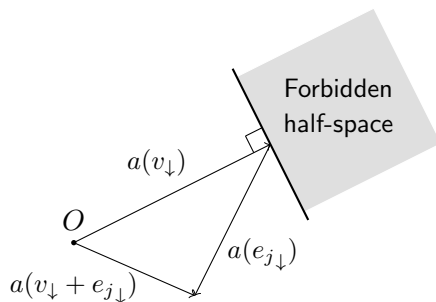

System of Equations: Algorithm

System of homogeneous LDEs: $a(x_{\downarrow}) = 0_{\downarrow}$.

Contejean-Devie algorithm:

- ▶ Start with the pair P, M where
 - ▶ $P = \{e_{1\downarrow}, \dots, e_{n\downarrow}\}$ is the set of potential solutions,
 - ▶ $M = \emptyset$ is the set of minimal nontrivial solutions.
- ▶ Apply repeatedly the rules:
 1. $\{v_{\downarrow}\} \cup P', M \implies P', M$,
if $v_{\downarrow} \gg u_{\downarrow}$ for some $u_{\downarrow} \in M$.
 2. $\{v_{\downarrow}\} \cup P', M \implies P', \{v_{\downarrow}\} \cup M$,
if $a(v_{\downarrow}) = 0_{\downarrow}$ and rule 1 is not applicable.
 3. $P, M \implies \{v_{\downarrow} + e_{j\downarrow} \mid v_{\downarrow} \in P, a(v_{\downarrow}) \cdot a(e_{j\downarrow}) < 0, j \in 1..n\}, M$,
if rules 1 and 2 are not applicable.
- ▶ If \emptyset, M is reached, return M .



Contejean-Devie Algorithm on an Example

$$\begin{cases} -x_1 + x_2 + 2x_3 - 3x_4 = 0 \\ -x_1 + 3x_2 - 2x_3 - x_4 = 0 \end{cases}$$

$$e_{1\downarrow} = (1, 0, 0, 0)^T \quad e_{2\downarrow} = (0, 1, 0, 0)^T$$

$$e_{3\downarrow} = (0, 0, 1, 0)^T \quad e_{4\downarrow} = (0, 0, 0, 1)^T$$

Start: $\{e_{1\downarrow}, \dots, e_{4\downarrow}\}, \emptyset$.

1. $\{v_{\downarrow}\} \cup P', M \implies P', M$,
if $v_{\downarrow} \gg u_{\downarrow}$ for some $u_{\downarrow} \in M$.
2. $\{v_{\downarrow}\} \cup P', M \implies P', \{v_{\downarrow}\} \cup M$,
if $a(v_{\downarrow}) = 0_{\downarrow}$ and rule 1 is not applicable.
3. $P, M \implies \{v_{\downarrow} + e_{j\downarrow} \mid v_{\downarrow} \in P, a(v_{\downarrow}) \cdot a(e_{j\downarrow}) < 0, j \in 1..n\}, M$,
if rules 1 and 2 are not applicable.



Contejean-Devie Algorithm on an Example

$$\begin{cases} -x_1 + x_2 + 2x_3 - 3x_4 = 0 \\ -x_1 + 3x_2 - 2x_3 - x_4 = 0 \end{cases}$$

$$e_{1\downarrow} = (1, 0, 0, 0)^T \quad e_{2\downarrow} = (0, 1, 0, 0)^T$$

$$e_{3\downarrow} = (0, 0, 1, 0)^T \quad e_{4\downarrow} = (0, 0, 0, 1)^T$$

Start: $\{e_{1\downarrow}, \dots, e_{4\downarrow}\}, \emptyset$.

1. $\{v_{\downarrow}\} \cup P', M \implies P', M$,
if $v_{\downarrow} \gg u_{\downarrow}$ for some $u_{\downarrow} \in M$.
2. $\{v_{\downarrow}\} \cup P', M \implies P', \{v_{\downarrow}\} \cup M$,
if $a(v_{\downarrow}) = 0_{\downarrow}$ and rule 1 is not applicable.
3. $P, M \implies \{v_{\downarrow} + e_{j\downarrow} \mid v_{\downarrow} \in P, a(v_{\downarrow}) \cdot a(e_{j\downarrow}) < 0, j \in 1..n\}, M$,
if rules 1 and 2 are not applicable.

$\begin{array}{c c} -1 & 1000 \\ -1 & \end{array}$	$\begin{array}{c c} 1 & 0100 \\ 3 & \end{array}$	$\begin{array}{c c} 2 & 0010 \\ -2 & \end{array}$	$\begin{array}{c c} -3 & 0001 \\ -1 & \end{array}$
--	--	---	--



Contejean-Devie Algorithm on an Example

$$\begin{cases} -x_1 + x_2 + 2x_3 - 3x_4 = 0 \\ -x_1 + 3x_2 - 2x_3 - x_4 = 0 \end{cases}$$

$$e_{1\downarrow} = (1, 0, 0, 0)^T \quad e_{2\downarrow} = (0, 1, 0, 0)^T$$

$$e_{3\downarrow} = (0, 0, 1, 0)^T \quad e_{4\downarrow} = (0, 0, 0, 1)^T$$

Start: $\{e_{1\downarrow}, \dots, e_{4\downarrow}\}, \emptyset$.

1. $\{v_\downarrow\} \cup P', M \implies P', M$,
if $v_\downarrow \gg u_\downarrow$ for some $u_\downarrow \in M$.
2. $\{v_\downarrow\} \cup P', M \implies P', \{v_\downarrow\} \cup M$,
if $a(v_\downarrow) = 0_\downarrow$ and rule 1 is not applicable.
3. $P, M \implies \{v_\downarrow + e_{j\downarrow} \mid v_\downarrow \in P, a(v_\downarrow) \cdot a(e_{j\downarrow}) < 0, j \in 1..n\}, M$,
if rules 1 and 2 are not applicable.

$\begin{array}{c c} -1 & 1000 \\ -1 & \end{array}$	$\begin{array}{c c} 1 & 0100 \\ 3 & \end{array}$	$\begin{array}{c c} 2 & 0010 \\ -2 & \end{array}$	$\begin{array}{c c} -3 & 0001 \\ -1 & \end{array}$
↓			
$\begin{array}{c c} 0 & 1100 \\ 2 & \end{array}$			



Contejean-Devie Algorithm on an Example

$$\begin{cases} -x_1 + x_2 + 2x_3 - 3x_4 = 0 \\ -x_1 + 3x_2 - 2x_3 - x_4 = 0 \end{cases}$$

$$e_{1\downarrow} = (1, 0, 0, 0)^T \quad e_{2\downarrow} = (0, 1, 0, 0)^T$$

$$e_{3\downarrow} = (0, 0, 1, 0)^T \quad e_{4\downarrow} = (0, 0, 0, 1)^T$$

Start: $\{e_{1\downarrow}, \dots, e_{4\downarrow}\}, \emptyset$.

1. $\{v_{\downarrow}\} \cup P', M \implies P', M$,
if $v_{\downarrow} \gg u_{\downarrow}$ for some $u_{\downarrow} \in M$.
2. $\{v_{\downarrow}\} \cup P', M \implies P', \{v_{\downarrow}\} \cup M$,
if $a(v_{\downarrow}) = 0_{\downarrow}$ and rule 1 is not applicable.
3. $P, M \implies \{v_{\downarrow} + e_{j\downarrow} \mid v_{\downarrow} \in P, a(v_{\downarrow}) \cdot a(e_{j\downarrow}) < 0, j \in 1..n\}, M$,
if rules 1 and 2 are not applicable.

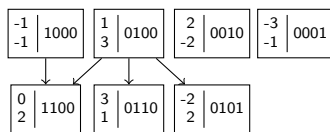

Contejean-Devie Algorithm on an Example

$$\begin{cases} -x_1 + x_2 + 2x_3 - 3x_4 = 0 \\ -x_1 + 3x_2 - 2x_3 - x_4 = 0 \end{cases}$$

$$e_{1\downarrow} = (1, 0, 0, 0)^T \quad e_{2\downarrow} = (0, 1, 0, 0)^T$$

$$e_{3\downarrow} = (0, 0, 1, 0)^T \quad e_{4\downarrow} = (0, 0, 0, 1)^T$$

Start: $\{e_{1\downarrow}, \dots, e_{4\downarrow}\}, \emptyset$.

1. $\{v_{\downarrow}\} \cup P', M \implies P', M$,
if $v_{\downarrow} \gg u_{\downarrow}$ for some $u_{\downarrow} \in M$.
2. $\{v_{\downarrow}\} \cup P', M \implies P', \{v_{\downarrow}\} \cup M$,
if $a(v_{\downarrow}) = 0_{\downarrow}$ and rule 1 is not applicable.
3. $P, M \implies \{v_{\downarrow} + e_{j\downarrow} \mid v_{\downarrow} \in P, a(v_{\downarrow}) \cdot a(e_{j\downarrow}) < 0, j \in 1..n\}, M$,
if rules 1 and 2 are not applicable.

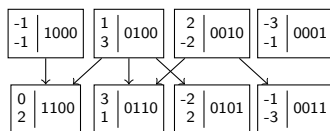

Contejean-Devie Algorithm on an Example

$$\begin{cases} -x_1 + x_2 + 2x_3 - 3x_4 = 0 \\ -x_1 + 3x_2 - 2x_3 - x_4 = 0 \end{cases}$$

$$e_{1\downarrow} = (1, 0, 0, 0)^T \quad e_{2\downarrow} = (0, 1, 0, 0)^T$$

$$e_{3\downarrow} = (0, 0, 1, 0)^T \quad e_{4\downarrow} = (0, 0, 0, 1)^T$$

Start: $\{e_{1\downarrow}, \dots, e_{4\downarrow}\}, \emptyset$.

1. $\{v_{\downarrow}\} \cup P', M \implies P', M$,
if $v_{\downarrow} \gg u_{\downarrow}$ for some $u_{\downarrow} \in M$.
2. $\{v_{\downarrow}\} \cup P', M \implies P', \{v_{\downarrow}\} \cup M$,
if $a(v_{\downarrow}) = 0_{\downarrow}$ and rule 1 is not applicable.
3. $P, M \implies \{v_{\downarrow} + e_{j\downarrow} \mid v_{\downarrow} \in P, a(v_{\downarrow}) \cdot a(e_{j\downarrow}) < 0, j \in 1..n\}, M$,
if rules 1 and 2 are not applicable.

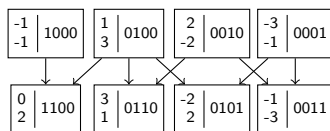

Contejean-Devie Algorithm on an Example

$$\begin{cases} -x_1 + x_2 + 2x_3 - 3x_4 = 0 \\ -x_1 + 3x_2 - 2x_3 - x_4 = 0 \end{cases}$$

$$e_{1\downarrow} = (1, 0, 0, 0)^T \quad e_{2\downarrow} = (0, 1, 0, 0)^T$$

$$e_{3\downarrow} = (0, 0, 1, 0)^T \quad e_{4\downarrow} = (0, 0, 0, 1)^T$$

Start: $\{e_{1\downarrow}, \dots, e_{4\downarrow}\}, \emptyset$.

1. $\{v_{\downarrow}\} \cup P', M \implies P', M$,
if $v_{\downarrow} \gg u_{\downarrow}$ for some $u_{\downarrow} \in M$.
2. $\{v_{\downarrow}\} \cup P', M \implies P', \{v_{\downarrow}\} \cup M$,
if $a(v_{\downarrow}) = 0_{\downarrow}$ and rule 1 is not applicable.
3. $P, M \implies \{v_{\downarrow} + e_{j\downarrow} \mid v_{\downarrow} \in P, a(v_{\downarrow}) \cdot a(e_{j\downarrow}) < 0, j \in 1..n\}, M$,
if rules 1 and 2 are not applicable.

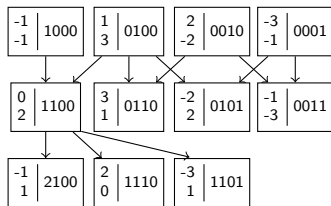

Contejean-Devie Algorithm on an Example

$$\begin{cases} -x_1 + x_2 + 2x_3 - 3x_4 = 0 \\ -x_1 + 3x_2 - 2x_3 - x_4 = 0 \end{cases}$$

$$e_{1\downarrow} = (1, 0, 0, 0)^T \quad e_{2\downarrow} = (0, 1, 0, 0)^T$$

$$e_{3\downarrow} = (0, 0, 1, 0)^T \quad e_{4\downarrow} = (0, 0, 0, 1)^T$$

Start: $\{e_{1\downarrow}, \dots, e_{4\downarrow}\}, \emptyset$.

1. $\{v_{\downarrow}\} \cup P', M \implies P', M$,
if $v_{\downarrow} \gg u_{\downarrow}$ for some $u_{\downarrow} \in M$.
2. $\{v_{\downarrow}\} \cup P', M \implies P', \{v_{\downarrow}\} \cup M$,
if $a(v_{\downarrow}) = 0_{\downarrow}$ and rule 1 is not applicable.
3. $P, M \implies \{v_{\downarrow} + e_{j\downarrow} \mid v_{\downarrow} \in P, a(v_{\downarrow}) \cdot a(e_{j\downarrow}) < 0, j \in 1..n\}, M$,
if rules 1 and 2 are not applicable.

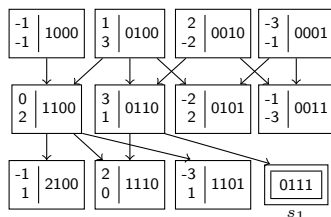

Contejean-Devie Algorithm on an Example

$$\begin{cases} -x_1 + x_2 + 2x_3 - 3x_4 = 0 \\ -x_1 + 3x_2 - 2x_3 - x_4 = 0 \end{cases}$$

$$e_{1\downarrow} = (1, 0, 0, 0)^T \quad e_{2\downarrow} = (0, 1, 0, 0)^T$$

$$e_{3\downarrow} = (0, 0, 1, 0)^T \quad e_{4\downarrow} = (0, 0, 0, 1)^T$$

Start: $\{e_{1\downarrow}, \dots, e_{4\downarrow}\}, \emptyset$.

1. $\{v_{\downarrow}\} \cup P', M \implies P', M$,
if $v_{\downarrow} \gg u_{\downarrow}$ for some $u_{\downarrow} \in M$.
2. $\{v_{\downarrow}\} \cup P', M \implies P', \{v_{\downarrow}\} \cup M$,
if $a(v_{\downarrow}) = 0_{\downarrow}$ and rule 1 is not applicable.
3. $P, M \implies \{v_{\downarrow} + e_{j\downarrow} \mid v_{\downarrow} \in P, a(v_{\downarrow}) \cdot a(e_{j\downarrow}) < 0, j \in 1..n\}, M$,
if rules 1 and 2 are not applicable.

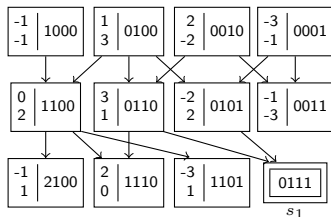

Contejean-Devie Algorithm on an Example

$$\begin{cases} -x_1 + x_2 + 2x_3 - 3x_4 = 0 \\ -x_1 + 3x_2 - 2x_3 - x_4 = 0 \end{cases}$$

$$e_{1\downarrow} = (1, 0, 0, 0)^T \quad e_{2\downarrow} = (0, 1, 0, 0)^T$$

$$e_{3\downarrow} = (0, 0, 1, 0)^T \quad e_{4\downarrow} = (0, 0, 0, 1)^T$$

Start: $\{e_{1\downarrow}, \dots, e_{4\downarrow}\}, \emptyset$.

1. $\{v_{\downarrow}\} \cup P', M \implies P', M$,
if $v_{\downarrow} \gg u_{\downarrow}$ for some $u_{\downarrow} \in M$.
2. $\{v_{\downarrow}\} \cup P', M \implies P', \{v_{\downarrow}\} \cup M$,
if $a(v_{\downarrow}) = 0_{\downarrow}$ and rule 1 is not applicable.
3. $P, M \implies \{v_{\downarrow} + e_{j\downarrow} \mid v_{\downarrow} \in P, a(v_{\downarrow}) \cdot a(e_{j\downarrow}) < 0, j \in 1..n\}, M$,
if rules 1 and 2 are not applicable.

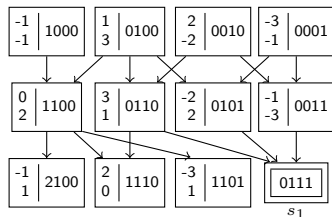

Contejean-Devie Algorithm on an Example

$$\begin{cases} -x_1 + x_2 + 2x_3 - 3x_4 = 0 \\ -x_1 + 3x_2 - 2x_3 - x_4 = 0 \end{cases}$$

$$e_{1\downarrow} = (1, 0, 0, 0)^T \quad e_{2\downarrow} = (0, 1, 0, 0)^T$$

$$e_{3\downarrow} = (0, 0, 1, 0)^T \quad e_{4\downarrow} = (0, 0, 0, 1)^T$$

Start: $\{e_{1\downarrow}, \dots, e_{4\downarrow}\}, \emptyset$.

1. $\{v_\downarrow\} \cup P', M \implies P', M$,
if $v_\downarrow \gg u_\downarrow$ for some $u_\downarrow \in M$.
2. $\{v_\downarrow\} \cup P', M \implies P', \{v_\downarrow\} \cup M$,
if $a(v_\downarrow) = 0_\downarrow$ and rule 1 is not applicable.
3. $P, M \implies \{v_\downarrow + e_{j\downarrow} \mid v_\downarrow \in P, a(v_\downarrow) \cdot a(e_{j\downarrow}) < 0, j \in 1..n\}, M$,
if rules 1 and 2 are not applicable.

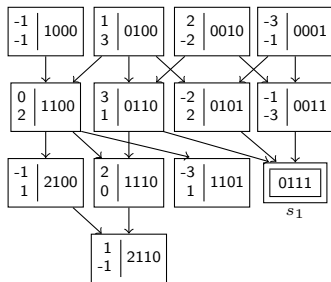

Contejean-Devie Algorithm on an Example

$$\begin{cases} -x_1 + x_2 + 2x_3 - 3x_4 = 0 \\ -x_1 + 3x_2 - 2x_3 - x_4 = 0 \end{cases}$$

$$e_{1\downarrow} = (1, 0, 0, 0)^T \quad e_{2\downarrow} = (0, 1, 0, 0)^T$$

$$e_{3\downarrow} = (0, 0, 1, 0)^T \quad e_{4\downarrow} = (0, 0, 0, 1)^T$$

Start: $\{e_{1\downarrow}, \dots, e_{4\downarrow}\}, \emptyset$.

1. $\{v_{\downarrow}\} \cup P', M \implies P', M$,
if $v_{\downarrow} \gg u_{\downarrow}$ for some $u_{\downarrow} \in M$.
2. $\{v_{\downarrow}\} \cup P', M \implies P', \{v_{\downarrow}\} \cup M$,
if $a(v_{\downarrow}) = 0_{\downarrow}$ and rule 1 is not applicable.
3. $P, M \implies \{v_{\downarrow} + e_{j\downarrow} \mid v_{\downarrow} \in P, a(v_{\downarrow}) \cdot a(e_{j\downarrow}) < 0, j \in 1..n\}, M$,
if rules 1 and 2 are not applicable.

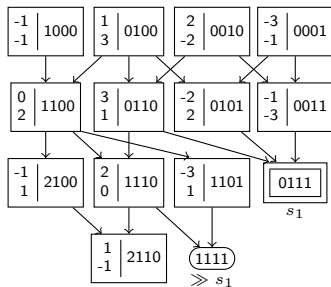

Contejean-Devie Algorithm on an Example

$$\begin{cases} -x_1 + x_2 + 2x_3 - 3x_4 = 0 \\ -x_1 + 3x_2 - 2x_3 - x_4 = 0 \end{cases}$$

$$e_{1\downarrow} = (1, 0, 0, 0)^T \quad e_{2\downarrow} = (0, 1, 0, 0)^T$$

$$e_{3\downarrow} = (0, 0, 1, 0)^T \quad e_{4\downarrow} = (0, 0, 0, 1)^T$$

Start: $\{e_{1\downarrow}, \dots, e_{4\downarrow}\}, \emptyset$.

1. $\{v_{\downarrow}\} \cup P', M \implies P', M$,
if $v_{\downarrow} \gg u_{\downarrow}$ for some $u_{\downarrow} \in M$.
2. $\{v_{\downarrow}\} \cup P', M \implies P', \{v_{\downarrow}\} \cup M$,
if $a(v_{\downarrow}) = 0_{\downarrow}$ and rule 1 is not applicable.
3. $P, M \implies \{v_{\downarrow} + e_{j\downarrow} \mid v_{\downarrow} \in P, a(v_{\downarrow}) \cdot a(e_{j\downarrow}) < 0, j \in 1..n\}, M$,
if rules 1 and 2 are not applicable.

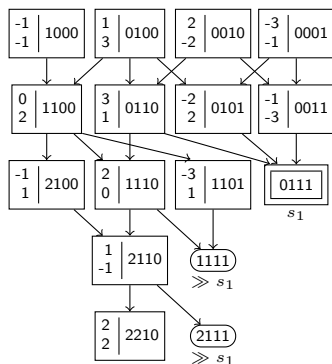

Contejean-Devie Algorithm on an Example

$$\begin{cases} -x_1 + x_2 + 2x_3 - 3x_4 = 0 \\ -x_1 + 3x_2 - 2x_3 - x_4 = 0 \end{cases}$$

$$e_{1\downarrow} = (1, 0, 0, 0)^T \quad e_{2\downarrow} = (0, 1, 0, 0)^T$$

$$e_{3\downarrow} = (0, 0, 1, 0)^T \quad e_{4\downarrow} = (0, 0, 0, 1)^T$$

Start: $\{e_{1\downarrow}, \dots, e_{4\downarrow}\}, \emptyset$.

1. $\{v_{\downarrow}\} \cup P', M \implies P', M$,
if $v_{\downarrow} \gg u_{\downarrow}$ for some $u_{\downarrow} \in M$.
2. $\{v_{\downarrow}\} \cup P', M \implies P', \{v_{\downarrow}\} \cup M$,
if $a(v_{\downarrow}) = 0_{\downarrow}$ and rule 1 is not applicable.
3. $P, M \implies \{v_{\downarrow} + e_{j\downarrow} \mid v_{\downarrow} \in P, a(v_{\downarrow}) \cdot a(e_{j\downarrow}) < 0, j \in 1..n\}, M$,
if rules 1 and 2 are not applicable.

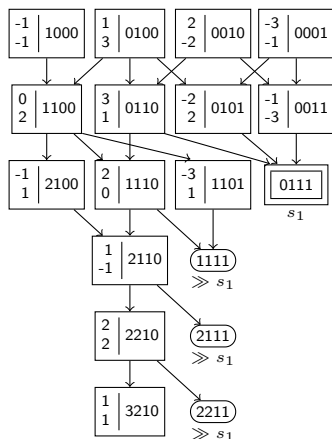

Contejean-Devie Algorithm on an Example

$$\begin{cases} -x_1 + x_2 + 2x_3 - 3x_4 = 0 \\ -x_1 + 3x_2 - 2x_3 - x_4 = 0 \end{cases}$$

$$e_{1\downarrow} = (1, 0, 0, 0)^T \quad e_{2\downarrow} = (0, 1, 0, 0)^T$$

$$e_{3\downarrow} = (0, 0, 1, 0)^T \quad e_{4\downarrow} = (0, 0, 0, 1)^T$$

Start: $\{e_{1\downarrow}, \dots, e_{4\downarrow}\}, \emptyset$.

1. $\{v_{\downarrow}\} \cup P', M \implies P', M$,
if $v_{\downarrow} \gg u_{\downarrow}$ for some $u_{\downarrow} \in M$.
2. $\{v_{\downarrow}\} \cup P', M \implies P', \{v_{\downarrow}\} \cup M$,
if $a(v_{\downarrow}) = 0_{\downarrow}$ and rule 1 is not applicable.
3. $P, M \implies \{v_{\downarrow} + e_{j\downarrow} \mid v_{\downarrow} \in P, a(v_{\downarrow}) \cdot a(e_{j\downarrow}) < 0, j \in 1..n\}, M$,
if rules 1 and 2 are not applicable.

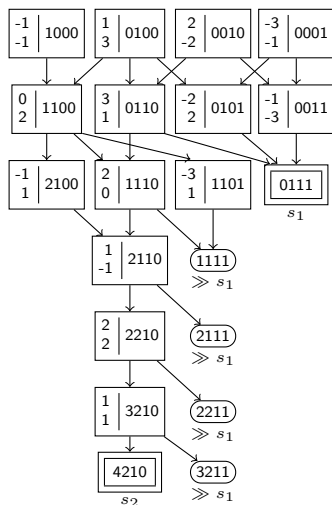

Contejean-Devie Algorithm on an Example

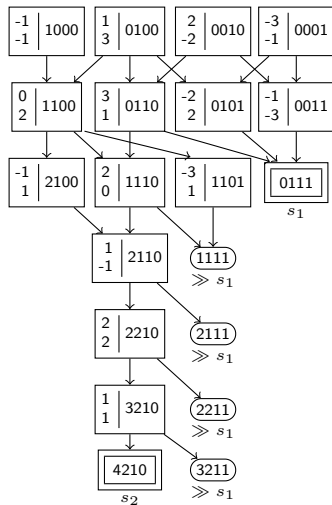
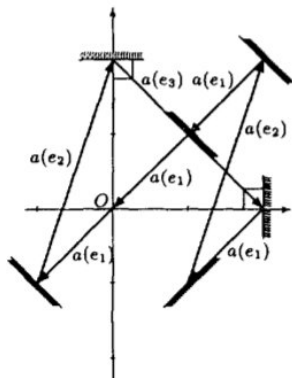

Properties of the Algorithm

$a(x_{\downarrow}) = 0_{\downarrow}$: An n -variate system of homogeneous LDEs.

$(e_{1\downarrow}, \dots, e_{n\downarrow})$: The canonical basis of \mathbb{N}^n .

$\mathcal{B}(a(x_{\downarrow}) = 0_{\downarrow})$: Basis in the set of nontrivial natural solutions of $a(x_{\downarrow}) = 0_{\downarrow}$.

Theorem

- ▶ *The Contejean-Devie algorithm terminates on any input.*
- ▶ *Let $(e_{1\downarrow}, \dots, e_{n\downarrow}), \emptyset \implies^* \emptyset, M$ be the sequence of transformations performed by the Contejean-Devie algorithm for $a(x_{\downarrow}) = 0_{\downarrow}$. Then*

$$\mathcal{B}(a(x_{\downarrow}) = 0_{\downarrow}) = M.$$



Notation

- ▶ $\|x_{\downarrow}\| = \sqrt{x_1^2 + \cdots + x_n^2}$.
- ▶ $|(s_1, \dots, s_n)| = s_1 + \cdots + s_n$.



Completeness

Theorem

Let $P_0, M_0 \implies^* \emptyset, M$ be the sequence of transformations performed by the Contejean-Devie algorithm for $a(x_\downarrow) = 0_\downarrow$ with $P_0 = (e_{1_\downarrow}, \dots, e_{n_\downarrow})$ and $M_0 = \emptyset$. Then $\mathcal{B}(a(x_\downarrow) = 0_\downarrow) \subseteq M$.

Proof.

Assume $s_\downarrow \in \mathcal{B}(a(x_\downarrow) = 0_\downarrow)$ and show that there exists a sequence of vectors

$$v_{1_\downarrow} = e_{j_{0_\downarrow}} \ll \dots \ll v_{k_\downarrow} \ll v_{k+1_\downarrow} = v_{k_\downarrow} + e_{j_{k_\downarrow}} \ll \dots \ll v_{|s_\downarrow|_\downarrow} = s_\downarrow$$

such that $v_{i_\downarrow} \in P_{l_i}$, where P_{l_i} is from the given sequence of transformations and $l_i < l_j$ for $i < j$.



Completeness

Theorem

Let $P_0, M_0 \implies^* \emptyset, M$ be the sequence of transformations performed by the Contejean-Devie algorithm for $a(x_\downarrow) = 0_\downarrow$ with $P_0 = (e_{1\downarrow}, \dots, e_{n\downarrow})$ and $M_0 = \emptyset$. Then $\mathcal{B}(a(x_\downarrow) = 0_\downarrow) \subseteq M$.

Proof (cont.)

For $e_{j0\downarrow}$, any basic vector $\ll s_\downarrow$ can be chosen. Such basic vectors do exist (since $s_\downarrow \neq 0_\downarrow$) and are in P_0 . Assume now we have $v_{1\downarrow} \ll \dots \ll v_{k\downarrow} \ll s_\downarrow$ with $v_{k\downarrow} \in P_{l_k}$. Then there exists $s_{k\downarrow}$ with $s_\downarrow = v_{k\downarrow} + s_{k\downarrow}$ and $0 = \|a(s_\downarrow)\|^2 = \|a(v_{k\downarrow})\|^2 + \|a(s_{k\downarrow})\|^2 + 2a(v_{k\downarrow}) \cdot a(s_{k\downarrow})$, which implies $a(v_{k\downarrow}) \cdot a(s_{k\downarrow}) < 0$.



Completeness

Theorem

Let $P_0, M_0 \implies^* \emptyset, M$ be the sequence of transformations performed by the Contejean-Devie algorithm for $a(x_\downarrow) = 0_\downarrow$ with $P_0 = (e_{1_\downarrow}, \dots, e_{n_\downarrow})$ and $M_0 = \emptyset$. Then $\mathcal{B}(a(x_\downarrow) = 0_\downarrow) \subseteq M$.

Proof (cont.)

Hence, there exists $e_{j_{k_\downarrow}}$ with $s_{k_\downarrow} \gg e_{j_{k_\downarrow}}$ such that $a(v_{k_\downarrow}) \cdot a(e_{j_{k_\downarrow}}) < 0$. We take $v_{k+1_\downarrow} = v_{k_\downarrow} + e_{j_{k_\downarrow}}$. Then $s_\downarrow \gg v_{k+1_\downarrow}$ and by rule 3, $v_{k+1_\downarrow} \in P_{l_{k+1}}$. After $|s_\downarrow|$ steps, we reach s . Hence, $s_\downarrow \in P_{l_{|s|}}$. Since $a(s_\downarrow) = 0$, application of rule 2 moves s_\downarrow to M . □



Soundness

Theorem

Let $P_0, M_0 \implies^* \emptyset, M$ be the sequence of transformations performed by the Contejean-Devie algorithm for $a(x_\downarrow) = 0_\downarrow$ with $P_0 = (e_{1\downarrow}, \dots, e_{n\downarrow})$ and $M_0 = \emptyset$. Then $M \subseteq \mathcal{B}(a(x_\downarrow) = 0_\downarrow)$.

Proof.

Any $s_\downarrow \in M$ is a solution. Show that it is minimal. Assume it is not: $s_\downarrow = s_{1\downarrow} + s_{2\downarrow}$, where $s_{1\downarrow}$ and $s_{2\downarrow}$ are non-null solutions smaller than s . Assume s_\downarrow was obtained during the transformations as $s_\downarrow = v_{i\downarrow} + e_{j_i\downarrow}$, where $v_{i\downarrow} \in P_i$. But then $v_{i\downarrow} \gg s_{1\downarrow}$ or $v_{i\downarrow} = s_{1\downarrow}$ or $v_{i\downarrow} \gg s_{2\downarrow}$ or $v_{i\downarrow} = s_{1\downarrow}$ and $v_{i\downarrow}$ is greater than an already computed minimal solution. Therefore, it should have been removed from P_i . A contradiction. \square



Termination

Theorem

Let $v_{1\downarrow}, v_{2\downarrow}, \dots$ be an infinite sequence satisfying the Contejean-Devie condition for $a(x_{\downarrow}) = 0_{\downarrow}$:

- ▶ u_1 is a basic vector and for each $i \geq 1$ there exists $1 \leq j \leq n$ such that $a(v_{i\downarrow}) \cdot a(e_{j\downarrow}) < 0$ and $v_{i+1\downarrow} = v_{i\downarrow} + e_{j\downarrow}$.

Then there exist v_{\downarrow} and k such that

- ▶ v_{\downarrow} is a solution of $a(x_{\downarrow}) = 0_{\downarrow}$, and
- ▶ $v_{\downarrow} \ll v_{k\downarrow}$.



Non-Homogeneous Case

Non-homogeneous linear Diophantine system with m equations and n variables:

$$\begin{cases} a_{11}x_1 + \cdots + a_{1n}x_n = b_1 \\ \vdots \\ a_{m1}x_1 + \cdots + a_{mn}x_n = b_m \end{cases}$$

- ▶ a 's and b 's are integers.
- ▶ Matrix form: $a(x_{\downarrow}) = b_{\downarrow}$.



Non-Homogeneous Case. Solving Idea

Turn the system into a homogeneous one, denoted S_0 :

$$\begin{cases} -b_1x_0 + a_{11}x_1 + \cdots + a_{1n}x_n = 0 \\ \vdots \qquad \qquad \qquad \vdots \qquad \qquad \qquad \vdots \\ -b_mx_0 + a_{m1}x_1 + \cdots + a_{mn}x_n = 0 \end{cases}$$

- ▶ Solve S_0 and keep only the solutions with $x_0 \leq 1$.
- ▶ $x_0 = 1$: a minimal solution for $a(x_\downarrow) = b_\downarrow$.
- ▶ $x_0 = 0$: a minimal solution for $a(x_\downarrow) = 0_\downarrow$.
- ▶ Any solution of the non-homogeneous system $a(x_\downarrow) = b_\downarrow$ has the form $x_\downarrow + y_\downarrow$ where:
 - ▶ x_\downarrow is a minimal solution of $a(x_\downarrow) = b_\downarrow$.
 - ▶ y_\downarrow is a linear combination (with natural coefficients) of minimal solutions of $a(x_\downarrow) = 0_\downarrow$.



Back to ACU-Unification

Theorem

The decision problem for ACU-Matching and ACU-unification is NP-complete.

